

Systems™ Scaffold

Tubular Scaffold Access Unit

Installation Instructions

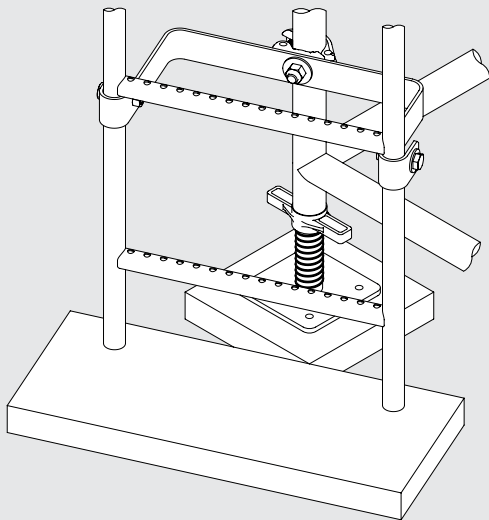

SYS

2 Tubular Scaffold Access Unit Installation Instructions

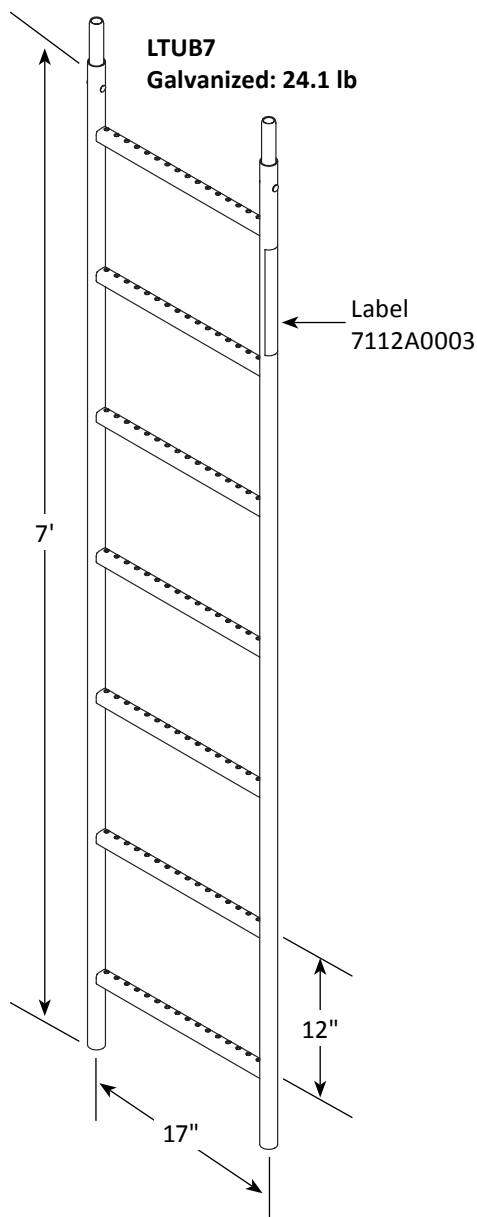

NOTICE

Please read and follow these instructions before installing, using or dismantling these scaffold access unit components. Serious injury or death can result from FAILURE to familiarize yourself, and comply, with all applicable safety requirements of federal, state, local and provincial regulations. Installation and dismantling must be done under supervision of a COMPETENT PERSON experienced in scaffold erection and dismantling. DO NOT use in any other fashion or with any other components without consulting BrandSafway or your BrandSafway dealer.

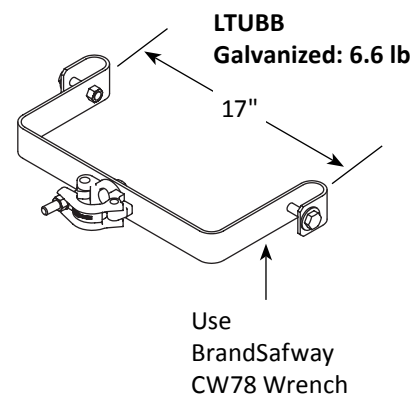
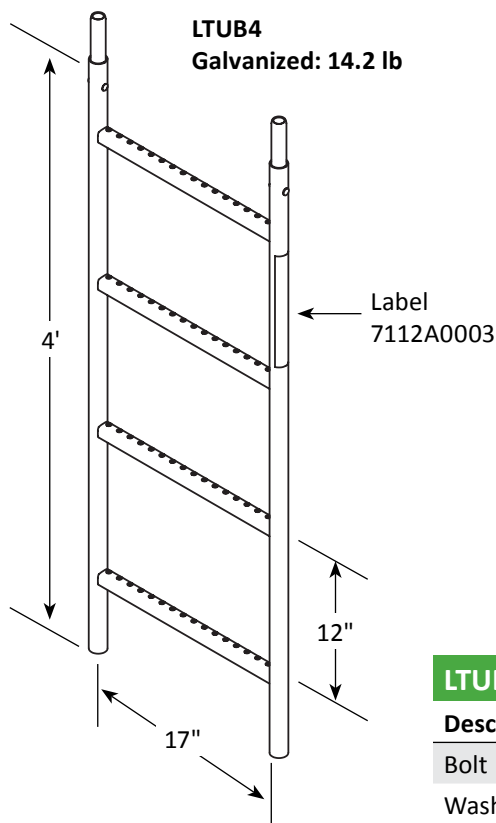

LTUBB Replacement Hardware

Description	Part No.
Bolt	5143A0822
Washer	5181A0010

Use these installation instructions for LTUB7, LTUB4 and LTUBB when used with BrandSafway Systems™, Sectional and Tube and Clamp scaffolds.

1. General

- Position scaffold access units in a location that avoids possible obstructions.
- Install scaffold access units while working from a scaffold platform and use fall protection per employers fall protection plan.
- Install scaffold access unit sections as scaffold is built.
- Install/use access gates as appropriate.
- Dismantle scaffold access units using reverse procedure.
- Follow appropriate BrandSafway Scaffold Safety Guidelines.

2. Initial Planning

- Cordon off work area to prevent access by others.
- Conduct a hazard assessment with your crew.
- Ensure fall arrest equipment has been inspected and provided along with all necessary personal protective equipment (PPE).
- When feasible, and in accordance with applicable regulation, workers to be tied-off to an adequate anchor when exposed to a fall.

3. Bottom Tubular Scaffold Access Unit

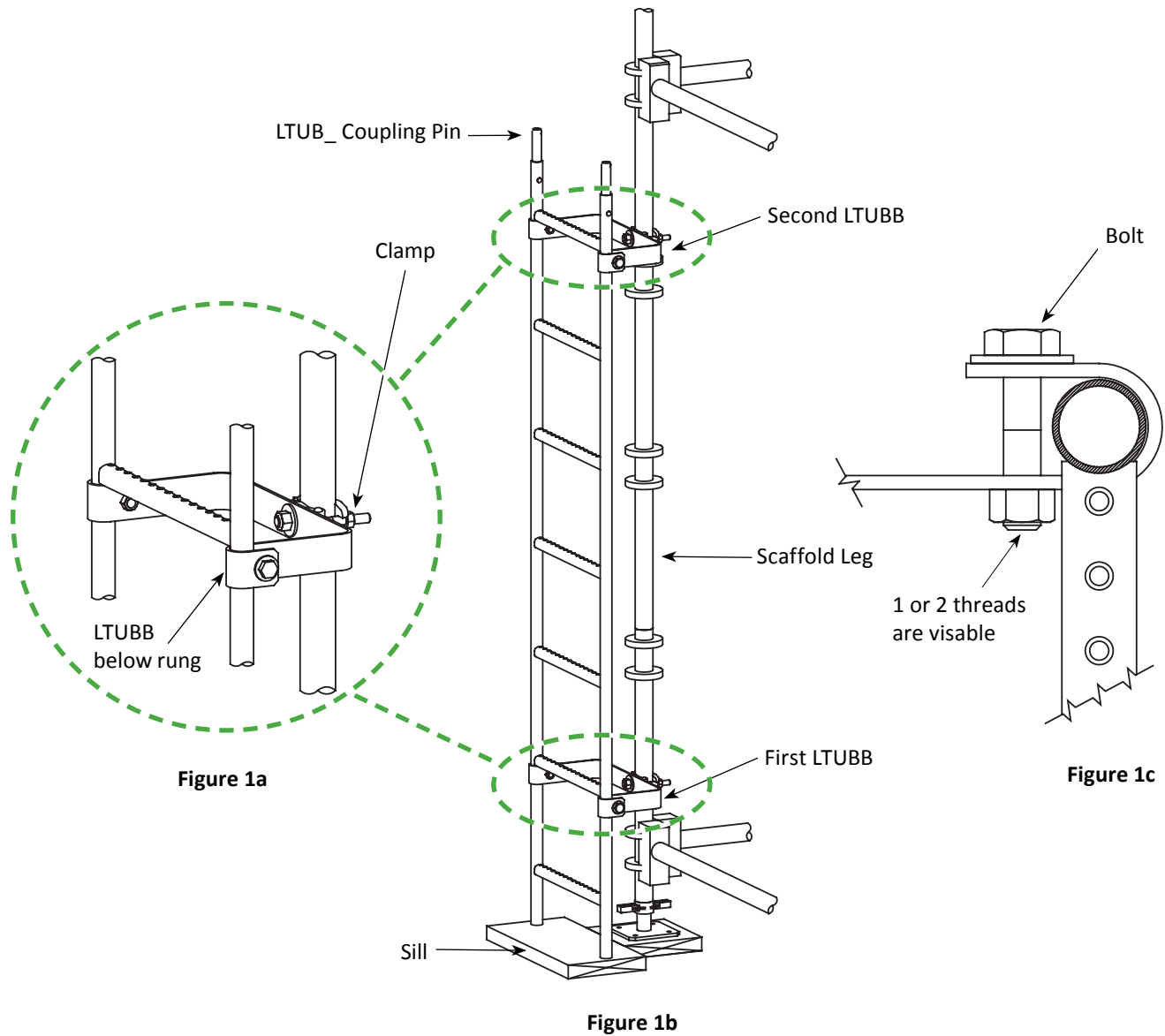

- Best practice is to position the first LTUB_ onto a sill on the ground (see figure 1b). Ensure the LTUB_ coupling pins are facing upwards.
- Only use hardware supplied with the LTUBB.
- Install the first bracket under a rung near the bottom of the LTUB_. Install the second bracket under a rung near the top. Be sure the brackets are snugged up against the underside of the rungs (See figures 1a and 1b).
- Tighten the (2) bolts in each bracket until they are snug and 1 or 2 threads are showing (See figure 1c). Do not over tighten.
- Secure the clamp around the scaffold leg and tighten the bolts on the clamp to approximately 45 ft-lb (See figure 1b).

4. Intermediate Tubular Scaffold Access Unit

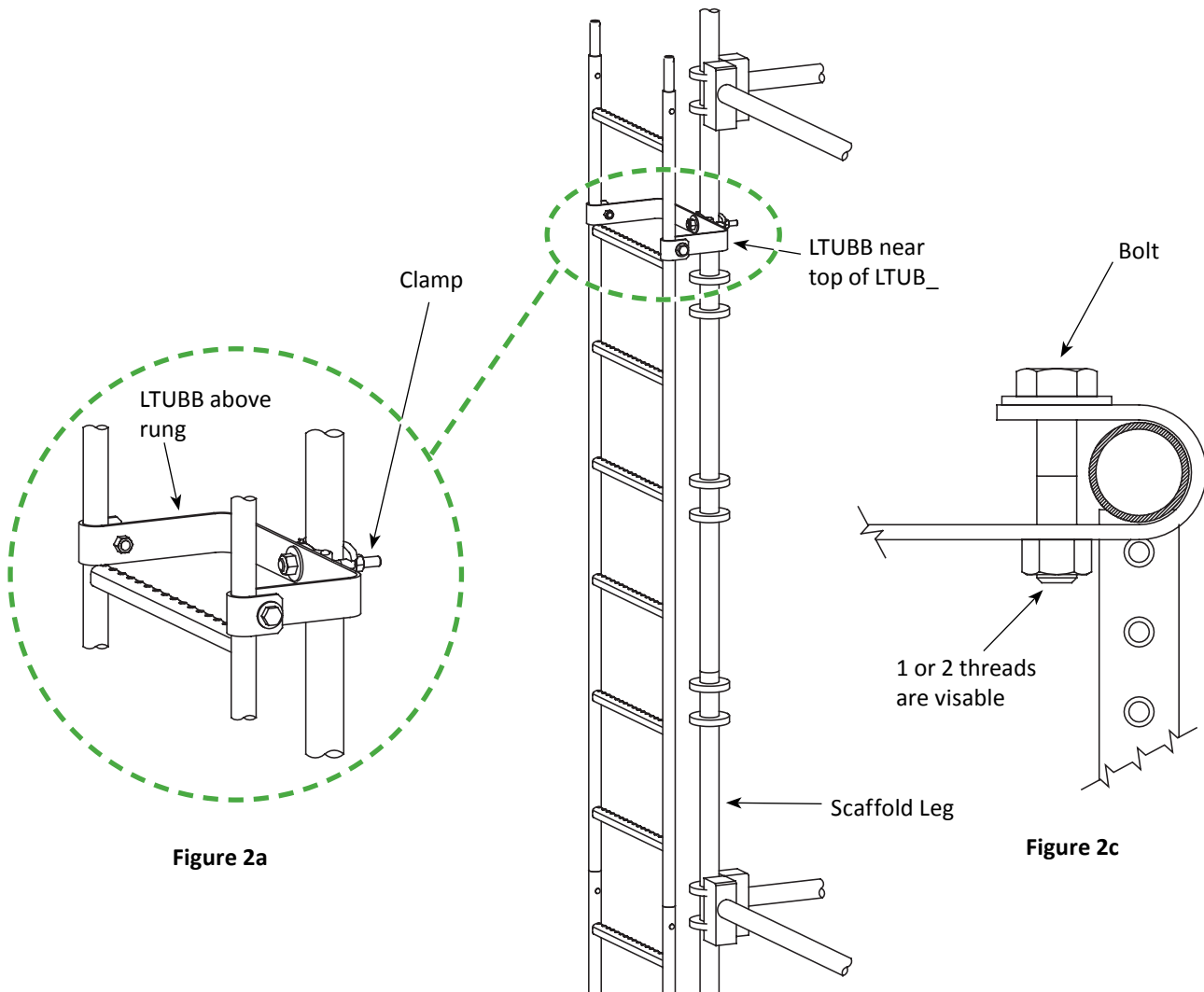

Figure 2a

Figure 2b

Figure 2c

- Pre-install one bracket on the LTUB_ above an upper rung and snug against the top of that rung (See figures 2a and 2b).
- Tighten the (2) bolts in the bracket until they are snug and 1 or 2 threads are showing (See figure 2c).
- Install the new LTUB_ with bracket installed by lowering it over the coupling pins of the LTUB_ below. Make sure it is fully seated (See figure 2b).
- Secure the clamp around the scaffold leg and tighten the bolts on the clamp to approximately 45 ft-lb.

5. Top Tubular Scaffold Access Unit

- A LTUB4 is available to allow approximately 3' extension above the upper work platform.
- Installation of the LTUB4 is the same as with all intermediate level LTUB's. Refer back to section 4.

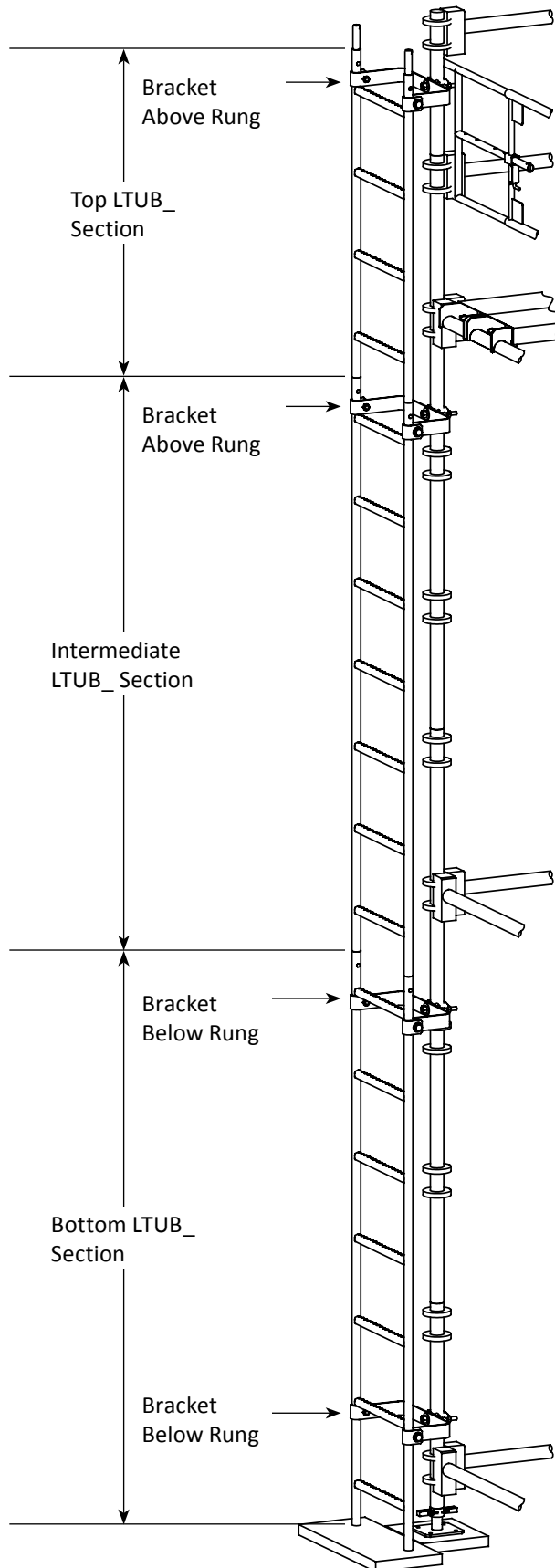

The page features a large rectangular area for notes, divided into two sections. The top section consists of approximately 10 horizontal lines for free-form writing. The bottom section is a large grid of small squares, suitable for technical drawing or structured data entry.

Safety is everyone's responsibility. Everyone's safety depends upon the design of scaffolds by a Qualified Person, erection and dismantling of scaffolds by Trained Erectors under the direct supervision of a Competent Person and use scaffolds by properly trained workers. Inspect your scaffold before each use to see that the assembly has not been altered and is safe for your use.

WARNING

SERIOUS INJURY OR DEATH CAN RESULT FROM YOUR FAILURE TO FAMILIARIZE YOURSELF AND COMPLY WITH ALL APPLICABLE SAFETY REQUIREMENTS OF FEDERAL, STATE, PROVINCIAL AND LOCAL REGULATIONS AND THESE SAFETY GUIDELINES BEFORE ERECTING, USING OR DISMANTLING THIS SCAFFOLD.

WARNING

BE SURE TO FULLY SEAT WEDGES IMMEDIATELY AFTER PLACING COMPONENT. WEDGES THAT ARE NOT FULLY SEATED WILL NOT SUPPORT DESIGN LOADS. FAILURE TO SEAT WEDGES COULD CAUSE SERIOUS INJURY OR DEATH.

Safety must come first!

BrandSafway equipment is designed and manufactured with the user in mind. The safety that goes into each piece of equipment, however, cannot offset carelessness on the part of the erector or the user. **Follow these safety guidelines in order to prevent injury** to the users of BrandSafway equipment. Scaffold design must include analysis of load carrying members by properly qualified personnel. BrandSafway component load capacity and weight information is available from your BrandSafway branch. Scaffold must be erected, used, moved, and disassembled only under the supervision of Competent Persons.

I. Erection of BrandSafway Systems™ Scaffold

A. Prior To Erection - All Scaffold Assemblies

1. Job site must be inspected to determine ground conditions, strength of supporting structure, proximity of electric power lines, overhead obstructions, wind conditions, and the need for overhead or weather protection. These conditions must be evaluated and adequately addressed.
2. Jobsite must be evaluated by a **Competent Person** for possible anchor locations for attaching a Personal Fall Arrest System. A new evaluation will need to be performed as site conditions change.
3. Post spacing and sill size can only be determined after the total loads to be imposed on the scaffold and the weight of the scaffold have been calculated.
4. Stationary scaffolds over 125 ft. in height must be designed by a professional engineer.
5. All equipment must be inspected to see that it is in good condition and is serviceable. Damaged or deteriorated equipment must not be used.

WARNING

NOT ALL SPECIES AND GRADES OF LUMBER CAN BE USED AS SCAFFOLD PLANK. WOOD PLANKS USED FOR SCAFFOLD PLATFORMS MUST BE GRADED AS SCAFFOLD PLANK BY AN APPROVED GRADING AGENCY, OR SPECIFICALLY MANUFACTURED FOR SCAFFOLD USE.

6. Scaffold plank must be inspected to see that it is graded as scaffold plank, is sound and in good condition, and inspected for saw cuts, cracks, notches, splits, delaminations and holes.
7. A Competent Person can deviate from these guidelines only if it can be shown that the resulting scaffold design complies with applicable codes and generally accepted scaffold engineering practices.
8. The scaffold assembly must be designed to comply with federal, state, provincial and local requirements.

WARNING

FALL ARREST EQUIPMENT ATTACHED TO SCAFFOLD MAY NOT PREVENT SERIOUS INJURY OR DEATH IF A FALL OCCURS.

B. Erection Of Fixed Scaffold

Scaffold must be erected, moved or disassembled only under the supervision of Competent Persons. Safety equipment, including safety glasses and hard hats, must be worn by all persons erecting, moving, dismantling or using Systems™ Scaffold.

1. All scaffold legs require the use of a base plate and a mudsill or other adequate firm foundation. Base plates must be in firm contact with the sills/foundation and scaffold legs and should be centered on the sills. Be especially careful when scaffolds are to be erected on soft or frozen ground. Any part of a building or structure used to support the scaffold must be capable of supporting the load to be applied.
2. Compensate for uneven ground by using screw jacks and base plates with sills. **Do not use** unstable objects or materials.
3. Use only tools recommended by BrandSafway, such as the Systems™ Pry Bar Hammer, for erection and dismantling.
4. Plumb and level scaffold until connections can be made with ease. Be sure scaffold stays plumb and level as erection progresses.
5. Fasten vertical posts together to prevent uplift.
6. Position horizontal members on both rings of each ring set and firmly seat wedges immediately. **Do not stand, lean, or put weight on horizontal members until the wedges are fully seated.** See Footnote 2.

WARNING

FULLY SEAT WEDGES IMMEDIATELY AFTER PLACEMENT.

7. Horizontal and/or vertical diagonal bracing is required to maintain a square and plumb scaffold structure.
8. Ties, guys, bracing and/or outriggers may be needed to assure a safe stable scaffold assembly. The height of the scaffold in relation to the minimum base dimension (length or width), wind loads, the use of brackets or cantilevered platforms and imposed scaffold loads determines the need for sway and stability bracing. The following general guidelines apply:
 - a. A scaffold must always be secured when the height of the scaffold exceeds 4 times the minimum base dimension (length or width). See Footnote 1.
 - b. Ties must be placed as near as possible to horizontal members. The bottom tie must be placed no higher than 4 times the minimum scaffold base dimension (length or width). Subsequent vertical tie placement will depend

upon the scaffold width. Scaffolds 3 ft. and narrower must be tied at vertical intervals no more than 20 ft. apart. Scaffolds wider than 3 ft. must be tied at vertical intervals no more than 26 ft. apart. The uppermost tie should be placed as close to the top as possible and, in no case, more than 4 times the minimum base width from the top. See Footnote 1.

WARNING

OUTRIGGERS, OR OTHER MEANS, MAY BE USED TO INCREASE THE MINIMUM BASE DIMENSION OF A SCAFFOLD TOWER. THE RESULTING BASE DIMENSION, HOWEVER, MAY NO LONGER BE THE MINIMUM (OR LIMITING) BASE DIMENSION.

- c. Horizontal ties must be placed at the ends of the scaffold runs and at no more than 30 ft. horizontal intervals in between.
- d. Ties must be installed as the erection progresses, and not removed until scaffold is dismantled to that height.
- e. Side brackets, cantilevered platforms, pulleys, hoist arms, enclosed scaffolds, sloped surfaces and windy conditions introduce overturning and uplift forces which must be considered and compensated for. These situations require additional bracing, tying or guying.
- f. Circular scaffolds erected completely around or within a structure may be restrained from tipping by use of "stand off" bracing members.
- g. A freestanding tower must be guyed at the intervals outlined above or otherwise restrained to prevent tipping or overturning.
9. Outrigger bays or outrigger units can be used to increase the minimum base width of freestanding towers. If used on a free standing tower, they must be installed on both sides of the tower.
10. Work platforms must be fully decked with platform units in good, sound condition. Platform units may be individual scaffold grade wood planks, fabricated plank, fabricated scaffold decks or fabricated scaffold platforms.
 - a. Scaffold platforms must be fully planked or decked between the front upright and guardrail post. Work platforms and walkways must be at least 18 in. wide.
 - b. Each end of each plank must overlap its support by a minimum of 6 in. or be cleated.
 - c. Each end of each platform 10 ft. long or less must overhang its supports by not more than 12 in. Each end of each platform longer than 10 ft. must overhang its supports by no more than 18 in. Larger overhangs must be guarded to prevent access to the overhang. Materials must not be stored on overhangs. Do not stand on platform overhangs.
 - d. Each plank on a continuous run scaffold must extend over its supports by at least 6 in. and overlap each other by at least 12 in.
 - e. Spans of 2 in. by 10 in. nominal scaffold grade plank must never exceed 10 ft. No more than one person must stand on an individual plank at one time. Loads on planks must be evenly distributed and not exceed the allowable loads for type of plank being used.

- f. Secure platform units to scaffold to prevent uplift caused by high winds or other job site conditions. Use latches, if supplied by platform manufacturer, or other suitable means.
- 11. Guardrails must be used on all open sides and ends of scaffold platforms. Both top and midrails are required. Local codes specify minimum heights where guardrails are required. Use guardrail at lower platform heights if falls can cause injury
- 12. Toeboards must be installed whenever people are required to work or pass under a scaffold platform. When materials are to be stacked higher than the toeboard, screening is required from the toeboard or platform to the top guardrail.
- 13. Access must be provided to all work platforms. If access is not available from the structure, access ladder units or stairways must be provided. When access ladder units are provided, a rest platform must be installed at vertical intervals of 35 ft. or less. Attachable ladders should extend at least 3 ft. above platforms. Install access ladder units as scaffold erection progresses.
- 14. Use fabricated decks or cleated plank to minimize platform interference in access areas.
- 15. **Do not** store materials on side or end bracket platforms.
- 16. Cantilevered platforms must be specifically designed for that purpose, the posts pinned to prevent uplift, and adequate ties provided to prevent overturning.
- 17. Materials must never be placed on cantilevered platforms unless the assembly has been designed to support material loads by a qualified person. These types of platforms cause overturning and uplift forces which must be compensated for.
- 18. After erecting scaffold, be sure screw jacks are in firm contact with vertical posts.
- 19. **Do not** use truss bearers without considering the loads to be supported. Do not cantilever truss bearers or other horizontal members.
- 20. Truss bearers with ring sets must be laterally braced.
- 21. **Do not** install platforms between free standing towers.
- 22. Material hoists and derricks should not be mounted on a scaffold unless the scaffold is specifically designed for that purpose.
- 23. **A Competent Person must check the entire scaffold assembly before use.** Thoroughly inspect the completed assembly to see that it complies with all safety codes, all fasteners are in place and tightened, it is level and plumb, work platforms are fully decked, guardrails are in place and safe access is provided.

C. Erection Of Rolling Scaffolds

The following additional precautions apply to the erection of rolling towers:

- 1. Height of the rolling tower must not exceed 4 times its minimum base dimension (length or width), or 40 ft., whichever is lower. See Footnote 1.
- 2. All casters must be secured to adapters with nuts and bolts.

WARNING

THE LOAD RATING OF THE CASTERS USED WILL LIMIT THE SIZE, CONFIGURATION, AND LOAD CAPACITY OF THE ROLLING TOWER.

- 3. Screw jacks must not increase the height of the scaffold by more than 12 in. Tower must be kept level and plumb at all times.
- 4. Horizontal diagonal bracing must be used at the bottom and top of rolling towers where the top work platform is more than 9 ft. above the supporting surface. When rolling towers are to be erected higher than 9 ft., the first brace must be no more than 2 ft. above the casters, the others at not greater than 21 ft. intervals above. Fabricated planks with hooks may be used as diagonal braces.
- 5. Platform units with hooks, or cleated planks, must be used on rolling towers.

II. Use Of Scaffolds

A. All Scaffolds

- 1. Each time before you use the scaffold, a Competent Person must: inspect the scaffold assembly to be sure it has not been altered, is assembled correctly, is level and plumb, all base plates are in firm contact with sills, all bracing is in place and securely fastened, all platforms are fully decked, all guardrails are in place, safe access is provided, it is properly tied and/or guyed, there are no overhead obstructions, there are no energized electric power lines within 10 ft. of the scaffold assembly, all wedges are firmly seated, all other member end connectors are firmly seated, all wedges are driven under ring sets, all retainers seated, all screw jacks are in contact with starter collars or posts. Correct any deficiencies prior to use.
- 2. All users must be trained prior to performing any work from the scaffold.
- 3. Use only proper access. Do not climb bracing, guardrails or vertical posts. Do not climb any scaffold component unless it is specifically designed for that purpose. If safe access is not provided, insist that it be provided.
- 4. Climb safely!
 - a. Face the rungs as you climb up or down.
 - b. Use both hands.
 - c. Do not try to carry materials while you climb.
 - d. Be sure of your footing and balance before you let go with your hands. Keep one hand firmly on frame or ladder at all times.
 - e. Clean shoes and rungs to avoid slipping.
- 5. **Do not** work on slippery platforms.
- 6. **Do not** overload platforms with materials. Special care must be taken when truss bearers are used.
- 7. **Do not** extend working heights by standing on planked guard rails, boxes, ladders or other materials on scaffold platforms.
- 8. **Do not** loosen, detach or remove any component of a scaffold assembly except under the supervision of a Competent Person. Components that have been removed must be replaced.
- 9. **Do not** erect scaffold on wagons, trucks or other wheeled vehicles.
- 10. **Do not** stand on platform overhangs. Stand only within the platform area; do not try to extend work area by leaning out over guardrailing.

B. Use Of Rolling Towers

All of the above precautions plus:

- 1. **A Competent Person** must inspect the scaffold prior to dismantling to make sure it is safe. Missing or damaged components such as ties, braces or plank may need to be installed
- 2. **Do not ride manually propelled rolling scaffold. No one must be on a rolling tower while it is being moved.**

- 3. Lock all casters before getting on a rolling tower. Casters must be locked at all times the scaffold is not being moved.
- 4. **Do not** bridge between rolling towers.
- 5. Remove all materials from scaffold before moving a rolling tower.
- 6. Be sure floor surface is clear of debris, obstructions or holes before moving scaffold.
- 7. Be sure there are no overhead obstructions or energized electric power lines in the path when moving a rolling tower.
- 8. Rolling towers must only be used on level surfaces.
- 9. Move rolling towers from the base level only. **Do not pull or push** from the top.

III. Dismantling Scaffolds

The following additional precautions apply when dismantling scaffolds:

WARNING

IT MAY BE NECESSARY TO ADD PARTS TO A SCAFFOLD BEFORE IT CAN BE DISMANTLED SAFELY.

- 1. **Prior to removal or loosening** of any component, consider the effect the removal of the component, or the loosening of a joint, will have on the strength of the remaining assembly.
- 2. Check to see if scaffold has been altered in any way which would make it unsafe. If so, reconstruct where necessary before beginning the dismantling process.
- 3. Use only proper access. Do not climb braces, guardrails, or vertical members. Do not climb scaffold components unless they are specifically designed for that purpose. Do not stand on platform overhangs.
- 4. **Do not** remove ties until scaffold above has been removed.
- 5. Visually inspect each plank to be sure it is supported on both ends and is safe to stand or work on.
- 6. **Do not** accumulate removed components or equipment on the scaffold.
- 7. Lower components in a safe manner as soon as dismantled. Do not throw components off scaffold.
- 8. Stockpile dismantled equipment in an orderly manner.
- 9. Remove component immediately after loosening wedges.

Understanding and following these safety guidelines will increase your personal safety and the safety of your fellow workers.

Footnote 1: California and some other states require a height-to-minimum base dimension (length or width) ratio of three-to-one (3:1). Refer to the governing codes for your job location.

Footnote 2: In California, horizontal members used as guardrails should be installed on the **top ring set only** to comply with the California 42 – 45 in. guardrail height requirement. **Fully seat wedges immediately after placement.**

All drawings in this guide are for illustrative purposes only. This guide is intended for general information purposes only. Because of the many variables which affect the performance of the product line, some of the information in this brochure may not apply. For specific applications, contact BrandSafway.

Note: All scaffolds shall be erected, modified and dismantled only under the supervision of a Competent Person. Erection, use, maintenance and disassembly must conform to current manufacturer's instructions as well as all federal, state, provincial and local regulations. Copies of complete Safety Guidelines for these and other products are available from BrandSafway without charge.