

SafLoad® Shoring

Product Selection Guide

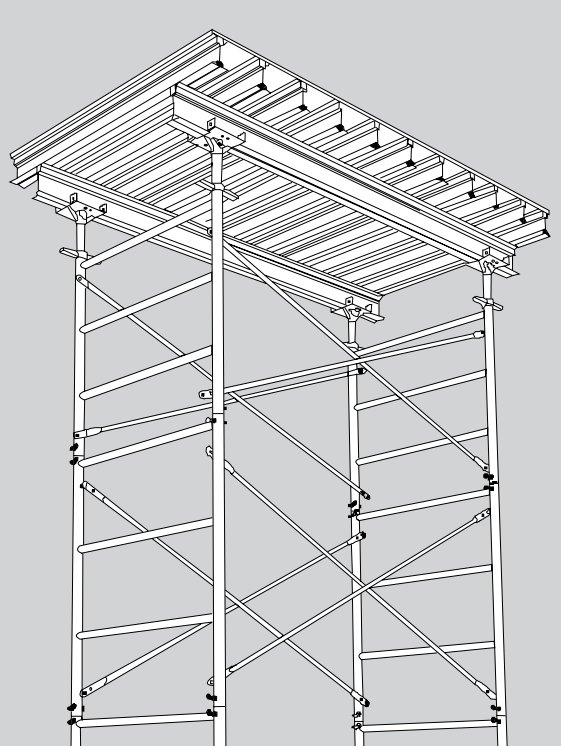

SHR

2 Components

Standard Heavy Duty Frames

| Part No. | Width | Height | Stud Spacing | Weight |
|----------|-------|--------|--------------|---------|
| SF44 | 4' | 4' | 3' | 47 lbs. |
| SF45 | 4' | 5' | 4' | 55 lbs. |
| SF46 | 4' | 6' | 4' | 68 lbs. |

All SafLoad® frames are painted grey and have 2³/₈" OD legs. Standard frames have a 1¹/₈" horizontal ledger.

All frames contain appropriate SIA warning labels.

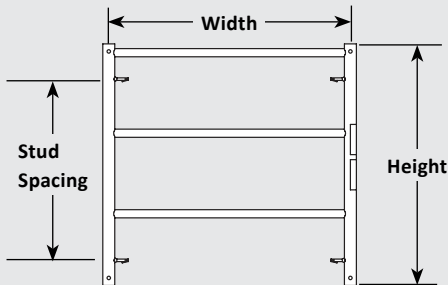

SF44

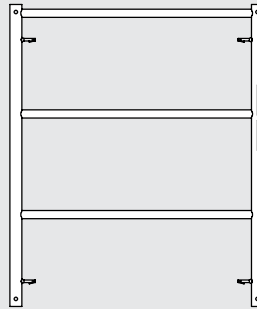

SF45

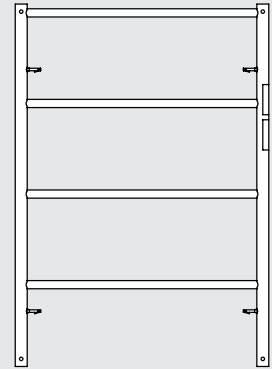

SF46

Load-bearing Ledger Frames

| Part No. | Width | Height | Stud Spacing | Weight |
|----------|-------|--------|--------------|---------|
| SF45LBL | 4' | 5' | 4' | 69 lbs. |
| SF46LBL | 4' | 6' | 4' | 77 lbs. |

All load-bearing ledger frames have a 2³/₈" ledger. Combined loads on ledger and legs.

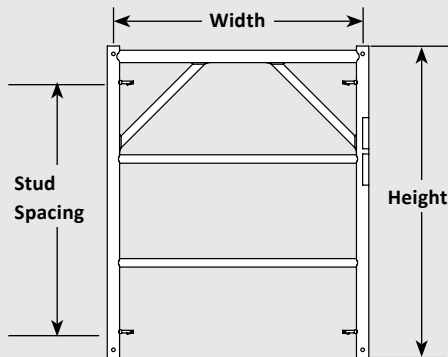

SF45LBL

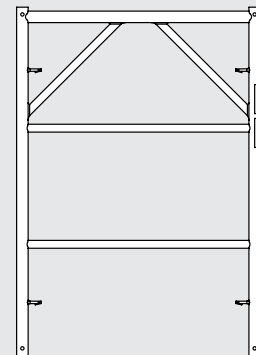

SF46LBL

2'-Wide Frames

| Part No. | Width | Height | Stud Spacing | Weight |
|----------|-------|--------|--------------|---------|
| SF24 | 2' | 4' | 3' | 38 lbs. |
| SF25 | 2' | 5' | 4' | 45 lbs. |
| SF26 | 2' | 6' | 4' | 55 lbs. |

Close leg spacing for high load applications. Perfect for beam support.

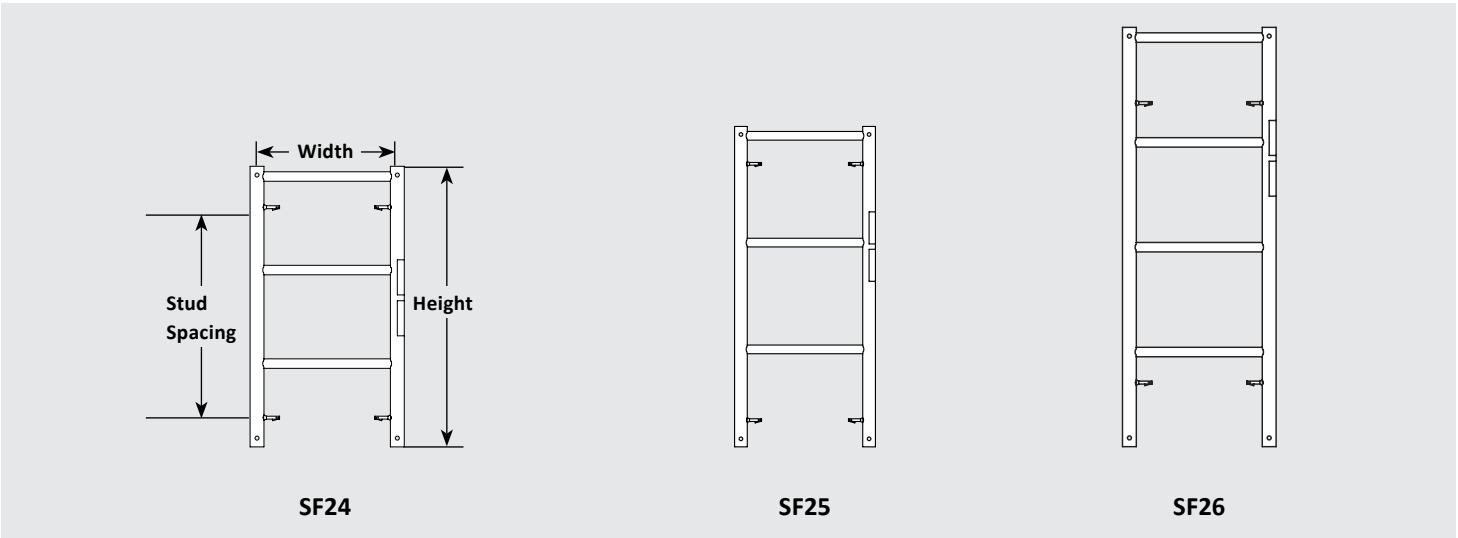

U-Head – Two Directional Stringer Support

| Part No. | Width | Height | Weight |
|----------|---------------------------------|----------------------------------|--------|
| SFU88TW | 8 ³ / ₈ " | 3 ³ / ₁₆ " | 7 lbs. |

Provides support for single or double 4"-wide flange beams.

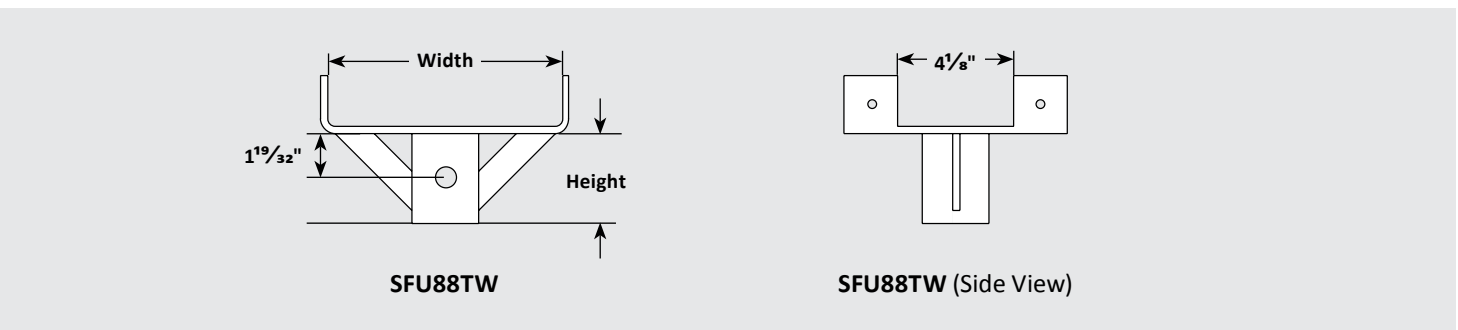

Double Hole Cross Braces – Dual Function

| Part No. | Hole Dimensions | Weight |
|-----------|------------------------------------|-----------|
| BDH3X4X4 | 67 ⁷ / ₈ " | 9.4 lbs. |
| BDH3X4X5 | 76 ²⁷ / ₃₂ " | 10.6 lbs. |
| BDH3X4X6 | 86 ¹⁷ / ₃₂ " | 11.8 lbs. |
| BDH3X4X7 | 96 ³ / ₄ " | 13.2 lbs. |
| BDH3X4X8 | 107 ¹ / ₃ " | 14.6 lbs. |
| BDH3X4X10 | 129 ¹ / ₄ " | 17.4 lbs. |

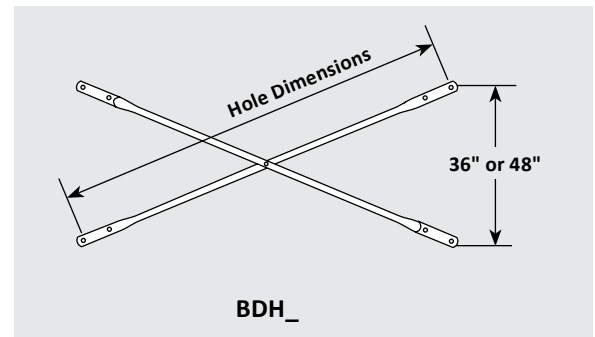

4 Components

Aluminum Stringers

| Part No. | Length | Weight |
|----------|--------|------------|
| ALS6 | 6' | 35.4 lbs. |
| ALS8 | 8' | 47.2 lbs. |
| ALS10 | 10' | 59 lbs. |
| ALS12 | 12' | 70.8 lbs. |
| ALS14 | 14' | 82.6 lbs. |
| ALS16 | 16' | 94.4 lbs. |
| ALS20 | 20' | 117.6 lbs. |
| ALS22 | 22' | 129.4 lbs. |

All Aluminum Stringers have a 4" top and bottom flange plus a convenient 2" x 2" nailer for use in special applications.

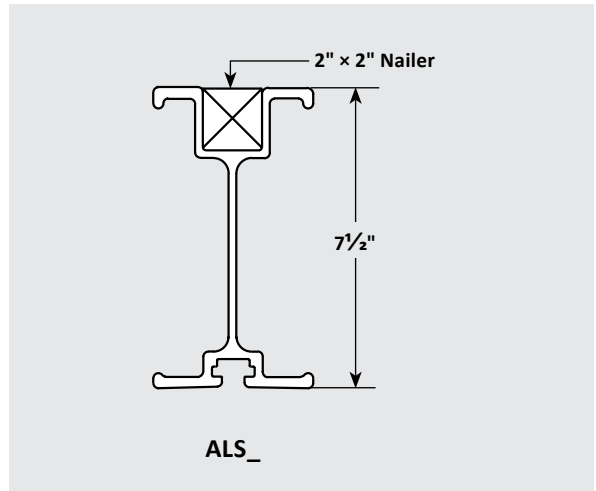

Aluminum Joists

| Part No. | Length | Weight |
|----------|--------|-----------|
| ALJ7 | 7' | 30.4 lbs. |
| ALJ9 | 9' | 39.1 lbs. |
| ALJ11 | 11' | 47.8 lbs. |
| ALJ13 | 13' | 56.5 lbs. |
| ALJ15 | 15' | 65.2 lbs. |
| ALJ17 | 17' | 73.8 lbs. |
| ALJ19 | 19' | 82.5 lbs. |
| ALJ21 | 21' | 91.2 lbs. |

All Aluminum Joists have a 4" bottom flange.

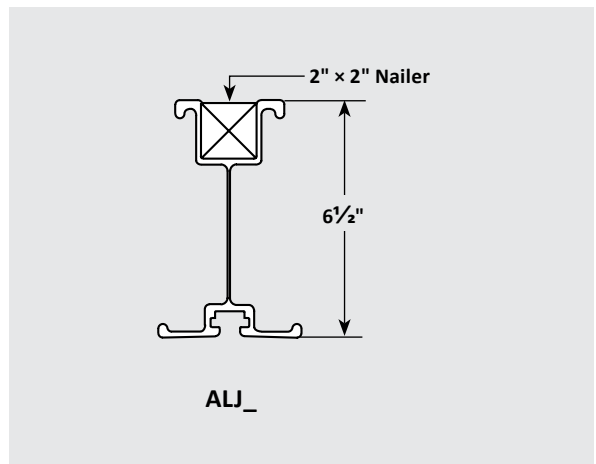

Additional Components

| Part No. | Description | Weight |
|----------|---------------------|----------|
| SFSJBP | Base Plate | 6.3 lbs. |
| SFCP | Coupling Pin | 1.3 lbs. |
| SFRP | Rivet Pin | 0.5 lbs. |
| SFHP | Hitch Pin | 0.3 lbs. |
| SFSJ36 | Screw Jack | 13 lbs. |
| SFSJ48 | Screw Jack* | 16 lbs. |
| ABC | Aluminum Beam Clamp | 0.5 lbs. |
| JBC | Junior Beam Clamp | 0.5 lbs. |

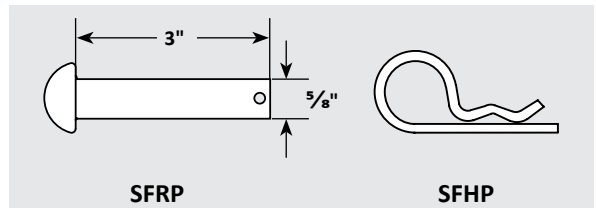

Quick and simple connections between frame and accessories.

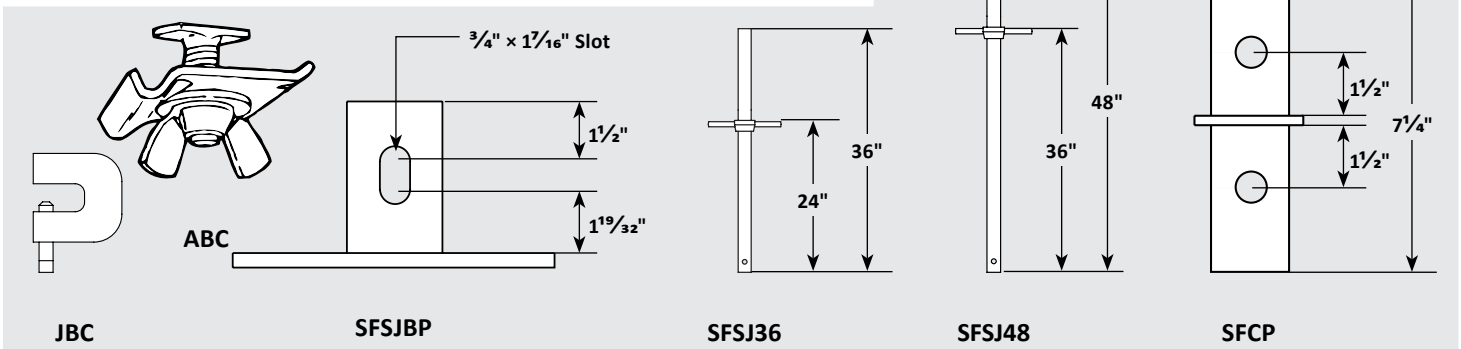

Fits onto Coupling Pins or Screw Jacks. Special slot ensures direct contact of jack and base.

All jacks are 1.9" O.D. and protected from corrosion. *Special 48" jack for offset applications.

Heavy-duty connection transfers load through stacked frames.

Assembly Diagram

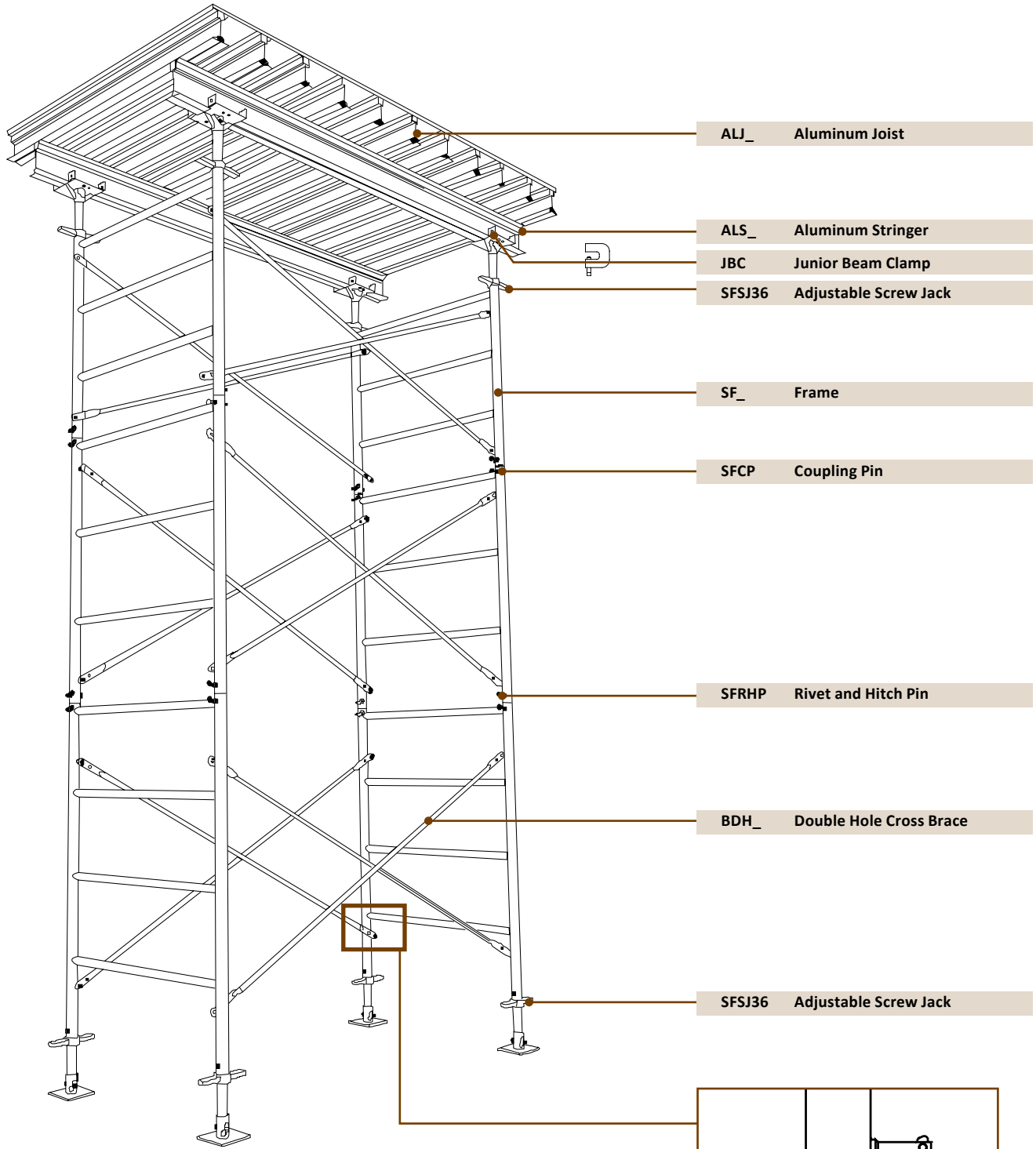

A detailed view of a Standard Flip Lock Stud. It shows a vertical rectangular bar with a circular hole near the bottom and a horizontal locking mechanism on the right side. The locking mechanism consists of a small rectangular plate with a circular hole, which fits into a corresponding hole in the vertical bar. This mechanism is used to lock cross-braces in place.

Standard Flip Lock Stud
(Positive, gravity-stable locking of cross braces)

6 Views and Working Loads

Section View

BrandSafway employs AutoCAD® software for flexible engineering solutions. Complete drawings may be mailed, faxed or e-mailed directly to the customer.

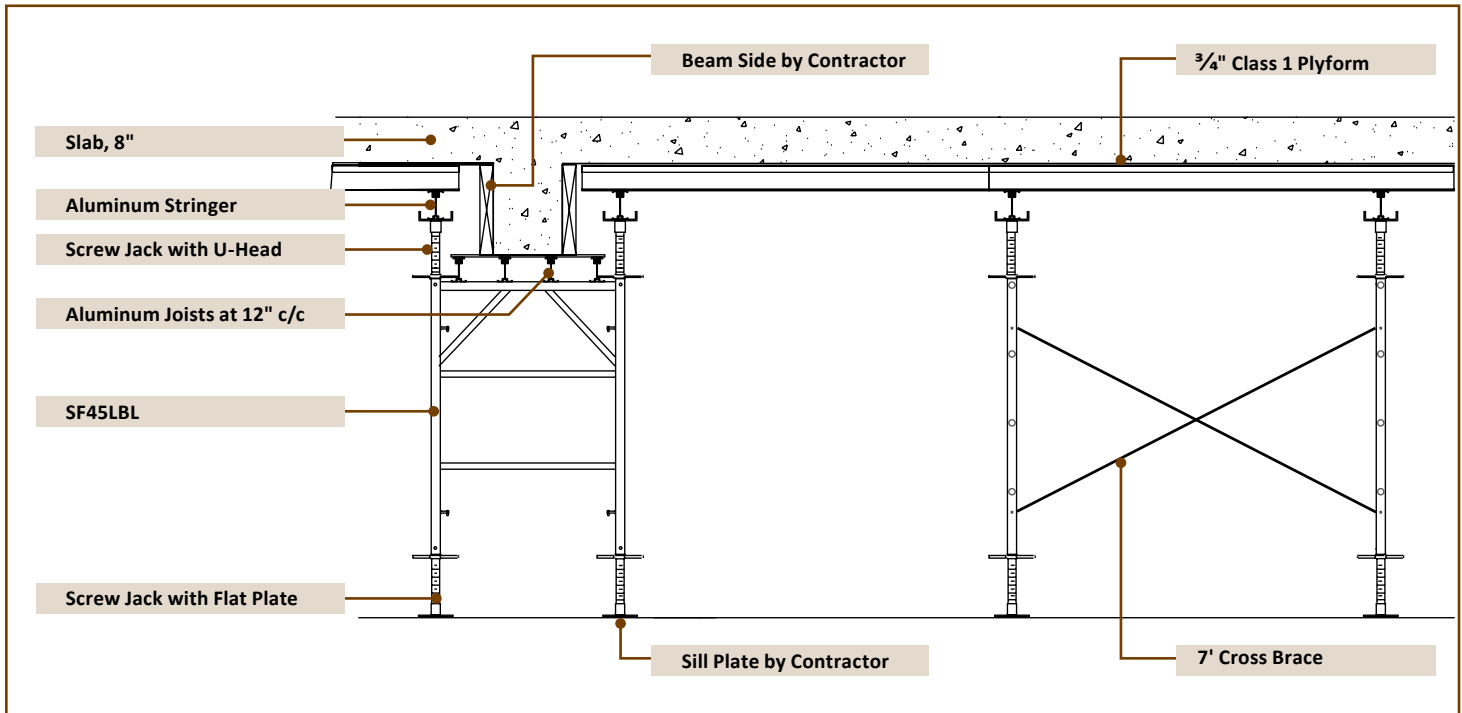

Section View

Allowable Working Loads (lbs./leg)

For towers over 60' high, consult with BrandSafway Engineering Department.

1. For combinations of SF44, SF45, SF46, SF24, SF25 and/or SF26 frames used in one tower, use SF46 loading below.
2. Total screw jack adjustment is the sum of the top and bottom screw jack extensions.
3. The allowable leg loads below reflect a 2.5:1 safety factor.

| No. of Tiers (frames) in Tower | | 1 | 2 | 3 | 4 | 5 | 6 | 7 | 8 | 9 | 10 | | |
|--------------------------------|---------|------------|---------------------------------------|--------|--------|--------|--------|--------|--------|-------|-------|-------|-------|
| SF44 | SF24 | Adjustment | Maximum Safe Working Leg Loads (lbs.) | | | | | | | | | | |
| | | 12" | 17,500 | 16,600 | 13,400 | 10,600 | 10,200 | 10,000 | 9,900 | 9,800 | 9,700 | 9,600 | |
| | | 24" | 14,800 | 13,700 | 11,900 | 9,500 | 9,100 | 8,700 | 8,600 | 8,500 | 8,400 | 8,300 | |
| | | 36" | 12,200 | 11,200 | 10,400 | 8,300 | 8,800 | 7,700 | 7,300 | 7,000 | 6,750 | 6,500 | |
| | | 48" | 10,500 | 10,300 | 9,750 | 8,000 | 7,700 | 7,400 | 7,200 | 7,000 | 6,750 | 6,500 | |
| SF45 | SF25 | SF45LBL | 12" | 15,800 | 14,900 | 13,400 | 10,600 | 10,200 | 10,000 | 9,900 | 9,800 | 9,700 | 9,600 |
| | | | 24" | 14,100 | 12,400 | 11,900 | 9,500 | 9,100 | 8,700 | 8,600 | 8,500 | 8,400 | 8,300 |
| | | | 36" | 11,700 | 10,700 | 10,400 | 8,300 | 8,000 | 7,700 | 7,300 | 7,000 | 6,750 | 6,500 |
| | | | 48" | 10,200 | 10,000 | 9,750 | 8,000 | 7,700 | 7,400 | 7,200 | 7,000 | 6,750 | 6,500 |
| SF46 | SF46LBL | 12" | 14,400 | 13,200 | 11,600 | 10,600 | 10,200 | 10,000 | 9,900 | 9,800 | 9,700 | 9,600 | |
| | | 24" | 12,400 | 11,100 | 10,800 | 9,500 | 9,100 | 8,700 | 8,600 | 8,500 | 8,400 | 8,300 | |
| | | 36" | 10,000 | 9,000 | 8,600 | 8,300 | 8,000 | 7,700 | 7,300 | 7,000 | 6,750 | 6,500 | |
| | | 48" | 8,500 | 8,400 | 8,200 | 8,000 | 7,700 | 7,400 | 7,200 | 7,000 | 6,750 | 6,500 | |



SafLoad® Shoring System Safety Guidelines

Shoring safety is everyone's responsibility!

Everyone's safety depends upon the proper erection and safe use of shoring. Inspect your shoring before each use to see that the assembly has not been altered and is safe for your use.

Post these shoring safety rules in a conspicuous place and be sure that all persons who erect, use or dismantle shoring are aware of them.

Follow all state, provincial, local and federal codes, ordinances and regulations pertaining to Shoring.

Inspect all equipment before using. Never use any equipment that is damaged, severely rusted or is missing locking devices. Any component which cannot be brought into proper alignment or contact with the component into or onto which it is intended to fit shall be removed and replaced.

A **shoring layout** shall be available and used on the jobsite at all times. Shoring design must include analysis of load carrying members by properly qualified personnel. BrandSafway shoring component load capacity and weight information is available from BrandSafway.

Inspect erected shoring and forming for conformity with layout and safety practices prior to pour, during pour, and after pour until concrete is set.

Consult your BrandSafway representative when in doubt. Shoring is our business. **Never take chances.**

WARNING

SERIOUS INJURY OR DEATH CAN RESULT FROM YOUR FAILURE TO FAMILIARIZE YOURSELF AND COMPLY WITH ALL APPLICABLE SAFETY REQUIREMENTS OF FEDERAL, STATE, PROVINCIAL AND LOCAL REGULATIONS. UNDERSTAND THESE SAFETY GUIDELINES BEFORE ERECTING, USING, OR DISMANTLING THIS SHORING.

I. Prior To The Pour

A. General

1. **Use BrandSafway's Recommended Safe Working Loads and Procedures For:**
 - a. Span, spacing and types of shoring members.
 - b. Types, sizes, heights and spacing of vertical shoring supports.
2. **Use lumber equivalent to the stress, species, grade and size specified on the layout.** Use only lumber that is in good condition. Do not splice timber members between their supports.
3. **Provide proper foundation** (sills, beams or cribbing) below base plates for the distribution of leg loads to concrete slabs or ground. Existing ground shall be level and thoroughly compact prior to erection of shoring to prevent settlement. Consideration must be given to potential adverse weather conditions throughout the pour cycle such as washouts, freezing and thawing of ground, etc. Consult a qualified soils engineer to determine the proper size foundation required for existing ground conditions.

4. **Do not make unauthorized changes or substitution of equipment;** always consult BrandSafway prior to making changes necessitated by jobsite conditions.
5. **Provide guardrail systems on all open sides and openings in formwork and slabs.**
6. **Access must be provided to all forming deck levels.** If it is not available from the structure, access ladders or stair towers must be provided. Access ladders must extend at least 3 ft. above formwork. Position or restrain ladders to prevent ladder or formwork displacement.

WARNING

FALL ARREST EQUIPMENT ATTACHED TO SHORING MAY NOT PREVENT SERIOUS INJURY OR DEATH IF A FALL OCCURS.

7. **If motorized concrete placement equipment is to be used,** be sure that lateral loads, vibration, and other forces have been considered and adequate precautions taken to assure stability.
8. **Plan concrete pouring methods and sequences** to ensure against unbalanced loading of the shoring equipment. Take all necessary precautions to avoid uplift of shoring components and formwork.
9. **Fasten all braces securely.**
10. **Check to see that all clamps, screws, pins and all other components are in a closed or engaged position.**
11. **Make certain that all base plates and shore heads are in firm contact with the foundation and forming material.**
12. **Use special precautions** when shoring to or from sloped surfaces.
13. **Avoid eccentric loads on U-Heads, and top plates** by centering stringers on these members.
14. **Avoid shock or impact loads** for which the shoring was not designed.
15. **Do not place additional temporary loads** (such as rebar bundles) on erected formwork or poured slabs without checking the capacity of the shoring and/or structure to safely support such additional loads.
16. The completed shoring setup shall have the specified bracing to give it lateral stability.
17. The erection of shoring should be under the supervision of an experienced and Competent Person.

B. Frame Shoring

1. **Follow the shoring layout drawing and do not omit required components.**
2. **Do not exceed the shore frame spacings or tower heights** as shown on the shoring layout.
3. **Shoring load must be carried on all legs.**
4. **Plumb and level all shoring frames** as the erection proceeds, and check plumb and level of shoring towers just prior to pour.
5. **Do not force** braces on frames to fit – level the shoring towers until proper fit can be made easily.

6. **Tie high towers of shoring frames together** with sufficient braces to make a rigid, solid unit (consult BrandSafway for recommendations). Shoring must always be secured when the height of the shoring towers exceed 4 times the minimum base width. **See Footnote 1.**
7. **Exercise caution** in erecting or dismantling free standing shoring towers to prevent tipping.
8. **Do not climb cross braces.**

C. Screw Jacks

1. **Use screw jacks** to adjust for uneven grade conditions, to level and accurately position the falsework and for easy stripping.
2. **Do not exceed BrandSafway's recommended maximum extension of screw jacks.** Keep screw jack extensions to a minimum for maximum load carrying capacity.
3. **Make certain that all screw jacks** are firmly in contact with the foundation and frame legs.

D. Post Shoring

1. **Plumb all post shores as the erection proceeds.** Check plumb of post shores just prior to pour.
2. **Post shores may require additional stability bracing.** Refer to manufacturer's instruction. Required bracing shall be installed as the shores are being erected.
3. **Devices which attach the external lateral stability bracing** shall be securely fastened to each post shore.
4. **Post shores more than one tier high should not be used.** Where greater shore heights are required, consult BrandSafway Engineering.

E. Horizontal Shoring

1. **Special consideration must be given to the installation of horizontal shoring beams:**
 - a. When sloped or supported by sloping ledgers (stringers).
 - b. When ledger (stringer) height/width ratio exceeds 2.5 to 1. Under no circumstances shall horizontal shoring beams bear on a single "two-by" ledger (stringer).
 - c. When eccentric loading conditions exist.
 - d. When ledger (stringer) consists of multiple members (i.e., double 2x6, 2x8, etc.).
 - e. When horizontal shoring beams are placed other than at right angles to their supports.
2. **Assure that bearing ends of shoring beams are properly supported** and that locking devices are properly engaged before placing any load on beams.
3. **Horizontal shoring beams should not be supported other than at the bearing prongs unless recommended by BrandSafway.** Cantilever "male end" of BrandSafway horizontal beams only. Cantilever shall not exceed 24".
4. **Do not nail beam bearing ends to ledger.**

5. **Provide and maintain adequate support** to properly distribute shoring loads. When supporting horizontal shoring beams on:
 - a. **Masonry Wall** – Ensure that masonry units have adequate strength. Brace walls as necessary.
 - b. **Ledgers** – Supported by walls using bolts, or other means, should be properly designed and installed per recommendation of supplier or job architect/engineer.
 - c. **Formwork** – Formwork shall be designed for the additional loads imposed by the shoring beams.
 - d. **Structural Steel Framework** – The ability of the steel to support all loading should be checked and approved by the responsible project architect/engineer.
 - e. **Steel Hangers** – Be sure the bearing ends fully engage on the hangers. The hangers shall be designed to conform to the bearing end and shall have a rated strength to safely support the shoring loads imposed. Hangers must be plate saddle rather than wire type. Check with manufacturer of hangers for specific application. (Follow hanger manufacturers' recommendations)

F. Joists and Stringers

1. Joists and stringers shall only overlap at a support.
2. All joists and stringers shall have full bearing at each support.
3. All stringers shall be secured to their supports.

G. Final Inspection

Be sure that:

1. There is a sound foundation under every leg.
2. All base plates and screw jacks are in firm contact with foundation.
3. Every component (including exterior bracing) agrees with the shoring layout as to type, span, number, location and size.
4. All shore pins are properly installed and fully seated.

5. All frames are plumb and braced to form towers and/or all posts are plumb and braced as required by user instructions.
6. All formwork follows forming layout, and horizontal beams fully bear on their supports.
7. All clamps, screws, pins and other fasteners (including locking devices on adjustable beams) are closed, tightened or engaged.



II. During the Pour

1. **Adjustment of shoring and/or post shores to raise formwork** shall not be made once the pour begins.
2. **Ensure pour sequence** will not cause an unbalanced load on shoring equipment.
3. Monitor possible movement of shoring components when placing concrete.

III. Removal

Loaded shoring equipment shall not be released or removed, including cross braces, until the approval of a qualified engineer has been received. Premature releasing or stripping of forms can cause failure. A qualified engineer must decide when and how stripping is to proceed. Weather conditions, variations in different parts of the structure and the setting qualities of the concrete all affect the stripping process.

IV. Reshoring

Definition: Reshoring means the construction operation in which shoring equipment is placed, as the original forms and shores are removed, in order to support partially cured concrete and construction loads.

1. Reshoring is one of the most critical operations in formwork; consequently, reshoring procedure must be designed and planned in advance by a qualified structural engineer and approved by the project

architect/engineer.

2. Slabs or beams which are to be reshored should be allowed to take their permanent deflection before final adjustment of reshoring equipment is made.
3. The reshoring shall be thoroughly checked by the architect/engineer to determine that it is properly placed and that it has the allowable load capacity to support the areas that are being reshored.
4. Equipment to be left in position for reshoring should be checked thoroughly by a qualified engineer. Horizontal shoring beams should never be used as a part of reshoring system. Extreme care must be taken to release the adjustment screws to a point where the slab takes its permanent deflection. The adjustment screws should then be tightened until contact is again made with the underside of the slab. In this manner the frame reshoring below will not be carrying the load of the slab that it had previously shored.

Footnote 1: California and some other states require a height-to-minimum base width ratio of three to one (3:1). Refer to the governing codes for your job location.

All drawings in this guide are for illustrative purposes only. This guide is intended for general information purposes only. Because of the many variables which affect the performance of the product line, some of the information in this brochure may not apply. For specific applications, contact BrandSafway.

Note: All scaffolds shall be erected, modified and dismantled only under the supervision of a Competent Person. Erection, use, maintenance and disassembly must conform to current manufacturer's instructions as well as all federal, state, provincial and local regulations. Copies of complete Safety Guidelines for these and other products are available from BrandSafway without charge.

Brand Industrial Services, Inc.
 1325 Cobb International Dr. Ste A-1
 Kennesaw, GA USA 30152
Toll free: 800 558 4772

For more information, visit our website
 at www.brandsafway.com